

Military Style Thumbscrew Hold-Down

CARLISLE
INTERCONNECT TECHNOLOGIES



Military Style Thumbscrew Hold-Down

FEATURES & BENEFITS

Function

- » Secure ratcheting locking mechanism
- » Easy engagement and dis-engagement

CONSTRUCTION

Materials

- » Corrosion resistant steel knob and threaded shaft with passivation and molybdenum disulfide lubricant
- » Beryllium copper wear washer
- » Aluminum hinge block with anodize finish

Fasteners

- » Installation via #6-32, #8-32, or M4 screws available

SPECIFICATIONS

Conforms to:

- » MS14108-4
- » MIL-F-85371
- » RoHS Compliant

Designed for use with equipment:

- » ARINC 404A
- » ARINC 704A
- » ARINC 600
- » ARINC 628
- » ARINC 738A-1

Weight

- » 62g Max

3D Models

- » STEP or IGES available upon request

Military Style Thumbscrew Hold-Down

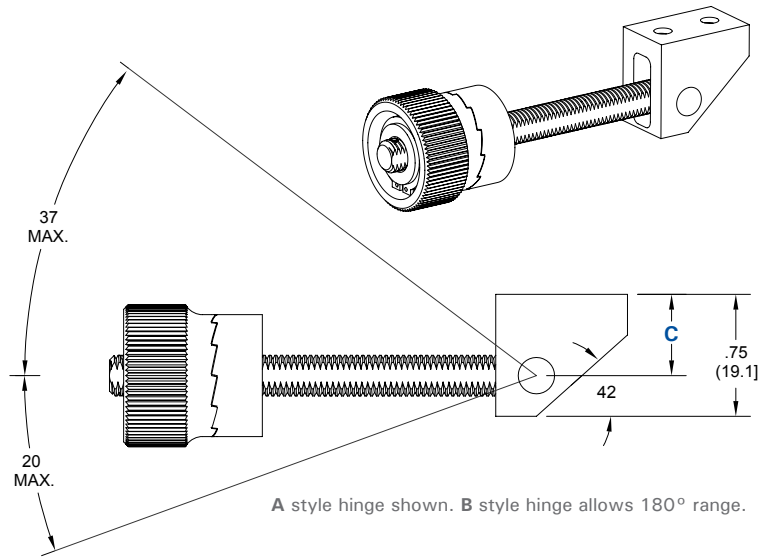
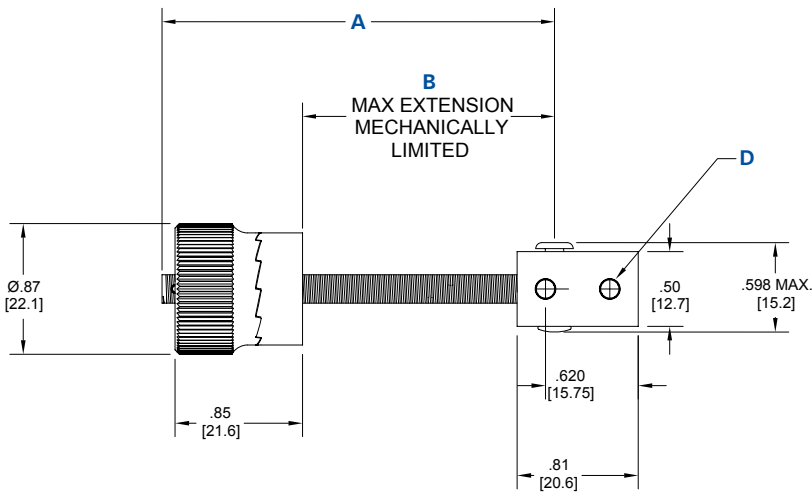

Hinge Block Options

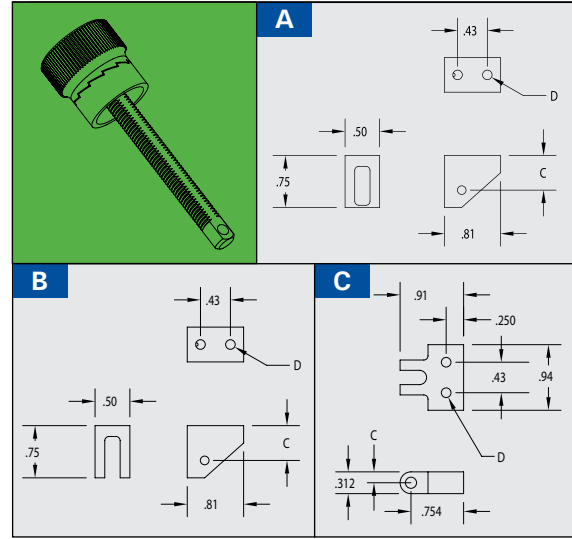

P/N	Hinge Block Included	A	B	C	D
		Length	Max Extension	Hinge Point	Mounting Holes
200-86446-101	- None -	2.75	1.83	0.50	0.125 Thru
S0076-105	A	2.75	1.83	0.50	#6-32
S0076-106	B	2.75	1.83	0.50	#6-32
S0076-108	A	2.12	1.18	0.50	#6-32
S0076-109	A	2.75	1.83	0.37	#6-32
S0076-110	A	2.41	1.47	0.50	#6-32
S0076-111	A	2.30	1.36	0.50	#6-32
S0076-112	A	2.12	1.18	0.37	#6-32
S0076-113	A	2.75	1.83	0.50	M4
S0138-101	C	2.75	1.83	0.16	#6-32
S0138-102	C	2.75	1.83	0.16	#8-32
S0138-103	C	1.88	0.94	0.16	#8-32

TESTED TO MEET/EXCEED THE FOLLOWING REQUIREMENTS

MIL-F-85371

Operational Shock

- » 15g, 11ms, ½ sine shock pulse (3 shocks in all 6 directions)

Static Load

- » 1,000 lbs applied at a 45° angle

Mechanical Endurance

- » 2,000 cycles

Fluid Susceptibility

- » Resistant to Hydraulic Fluid & Oil

Salt Spray

- » ASTM B117 for 168 hours

Sand & Dust

- » MIL-STD-810C, Method 510.1

Thermal Shock

- » MIL-STD-202G, Method 107G, Test Condition B

RTCA/DO-160G

Crash Safety, Impulse

- » 20Gs per §7.3.1 of RTCA/DO-160G (1 shock in all 6 directions)

Robust Random Vibration

- » Cat R, Curves B3 & B4, per §8.7.2 of RTCA/DO-160G

High Level - Short Duration

- » Cat H, Curve R, per §8.6 of RTCA/DO-160G

Windmilling

- » One Sweep (30.5 – 9.5 Hz) for 48 minutes between 0.5g & 2.92g